

RR Fischer Product Portfolio

Our Solution for Any Intralogistic Challenge

RR FISCHER
We stock it all.



RR FISCHER We stock it all.

Table of Contents

Introduction	2
Warehousing and Logistics Platforms	4
Mezzanines	6
Logistics Platforms	8
Mezzanine Building Set	12
Racking Systems Overview	14
Cantilever Racks by Fischer	16
Small Cantilever Racks for Indoor Use	22
Heavy Cantilever Racking – Hot-Rolled	23
Cantilever Racks for Outdoor Use	24
Cantilever Racking Kit	26
Pallet Racking by Fischer	30
Rung Shelves	32
Heavy Duty Racking Solutions Developed by Fischer	33
Record Shelves	34
Sheet Metal Shelves	35
Dynamic Storage Shelves	36
Pallet Conveyors by Rack & Roll	38
Pushback Trolley System by AQS	42
XXL Conveyors by AQS	44
Carton Flow Systems by AQS	46
Carton Flow Level System S	50
Carton Flow Level System M	51
Carton Flow Level System L	52
Carton Flow Level System XL	53

Introduction

Comprehensive Solutions for Modern Warehousing and Logistics Processes

Efficient warehousing and logistics solutions are a key success factor in the project business. As the sales company for our manufacturers, we distribute high-quality storage and logistics platforms, shelving systems, and dynamic storage systems that are specifically designed to meet the requirements of our end customers.

This product catalog provides you with a structured overview of our portfolio as a technical basis for consulting, project planning, and tendering. Our systems are modular in design, individually configurable, and can be flexibly integrated into a wide variety of customer projects, from standard applications to complex special solutions.

With a high level of vertical integration, comprehensive technical expertise, and clearly defined interfaces, we support you in implementing your projects efficiently, economically, and reliably.

We stock it all.

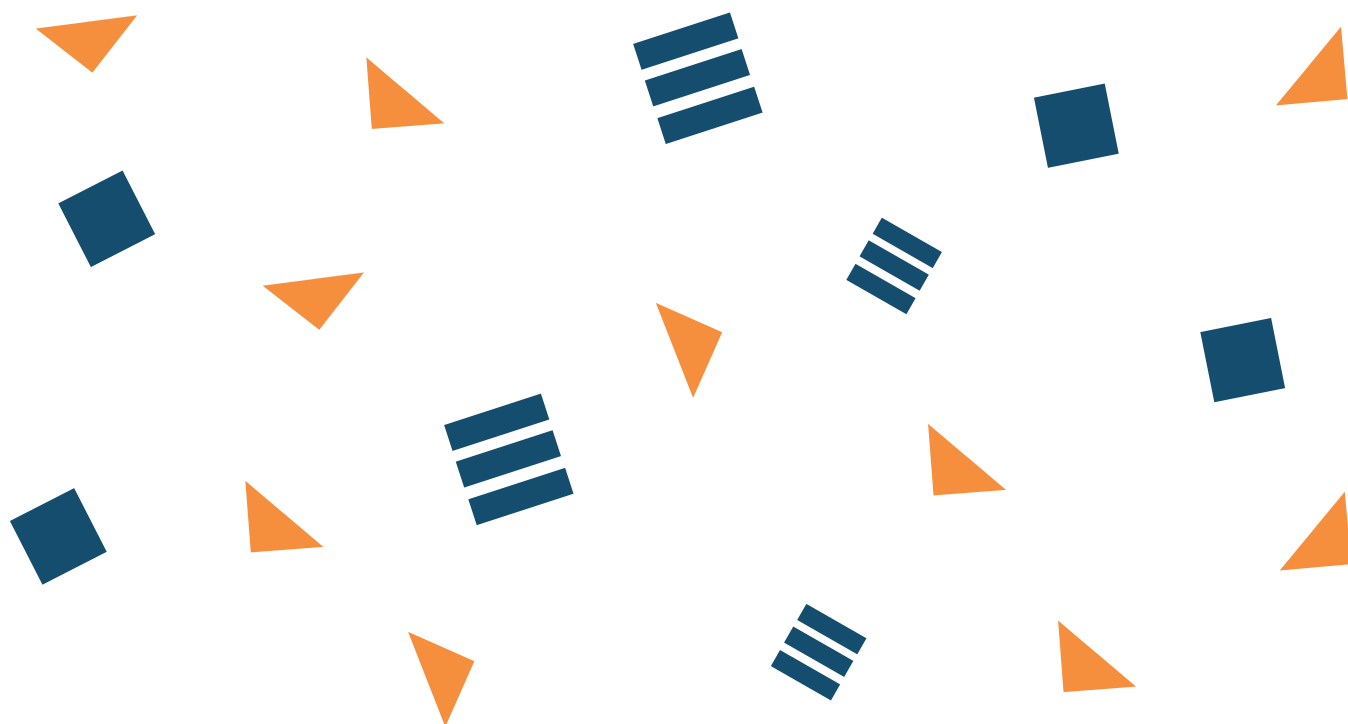

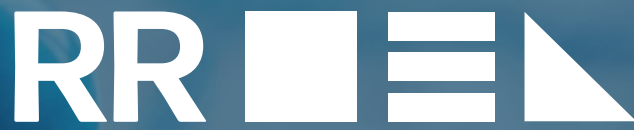
The logo consists of the letters 'RR' followed by a square, three horizontal lines, and a right-angled triangle. It is positioned between two horizontal white lines.

RR ■ ■ ■ ▽

FISCHER

We stock it all.

Warehousing and Logistics Platforms

For Optimized Processes and Accessibility

By using mezzanine and logistics platforms, you can optimize your processes, improve the accessibility of goods, and significantly reduce processing times. They also enable better organization of the warehouse, as different products can be stored on different levels.

The variety of designs and materials makes it possible to adapt these platforms to your specific requirements and space conditions. Efficiency is further increased with the integration of modern technologies, such as automated storage systems.

→ Solutions Available in Our Product Portfolio



Logistic Platforms and Mezzanines by Fischer

High, Higher, More Stable

Fischer storage platforms are custom-made to suit your individual requirements. The use of hot-rolled steel enables us to construct platforms that can withstand even the heaviest loads and have large spans.

A wide range of different floor coverings and extensive accessories round off the portfolio.



Mezzanine Building Set

Build Your Own Platform – Modular, Adaptable, Ready to Deploy

Our mezzanine building set allows you to build and extend your mezzanine based on your needs.

We keep all parts in stock and can ship them within one week all over Europe. The flexibility of the design allows various shapes and designs.



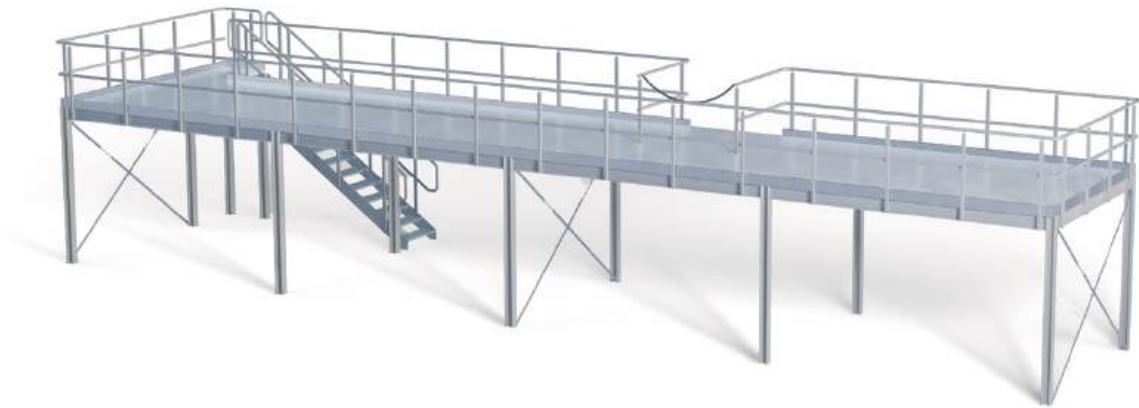

Mezzanines – High, Higher, More Stable

The use of storage and logistics platforms allows you to optimize your processes, improve the accessibility of goods, and significantly reduce processing times. They also enable better organization of the warehouse, as different products can be stored on different levels.

The variety of designs and materials allows these platforms to be adapted to your specific requirements and space conditions. Efficiency is further increased through the integration of modern technologies, such as automated storage systems.

→ Technical Specifications

- Up to 15 m span
- Up to 3,000 kg/m²
- Up to 5 floors and more
- With/without shelving system
- Can be accessed by electric pallet trucks if required
- Powder-coated or hot-dip galvanized

→ Our Strengths

- Can also be used for heavy surface and point loads
- Can be customized to local conditions
- Can be implemented at short notice
- Reduced number of diagonal braces

→ Areas of Application

- Logistics steel construction
- Additional storage/office space
- Additional production space

→ Additional Components

- Stairs, walkways, ladders, catwalks
- Railings and fences
- Heavy-duty shelves



Railings

Our railings are available in a wide variety of designs.

Handrails in Sendzimir galvanized or powder-coated. In addition to our standard colors, all RAL colors are available. With or without mesh panels.



Transfer Station (with Chain)

The transfer station can be ordered in the dimensions you need. The simplicity and flexibility offer you multiple options.

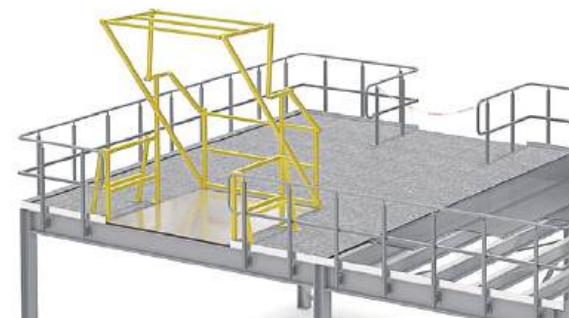

Transfer Station Security Gate

The transfer station with security gate is the safest solution to design the handover process for goods. It only allows access to the mezzanine for goods if the gate is closed.



Stairs

Would you like to use the stairs to create a small highlight or integrate them harmoniously into the overall picture? Our stairs adapt to your architecture. The steps are available in grating, checker plate, or multiplex beech on request. Railings and other steel components are available in your desired RAL color or Sendzimir galvanized.



Ladders

Our ladders are available with or without back protection.



Logistic Platforms

With our customized logistics steel platforms, we create the ideal substructure for conveyor technology, sorters, and picking stations. As a high-performance partner, we support logistics projects throughout Europe - from planning and manufacturing to installation. Our wide range of services includes steel construction, floor coverings, staircases, fences, railings, walkways, and catwalks, which are individually tailored to your requirements.

Thanks to our experienced project team of structural engineers, approval technicians, designers, assembly planners, and project managers, we guarantee precise and timely implementation. Equipped with all the necessary approvals and certificates, we also implement complex steel construction projects up to a project size of 1,000 tons - reliably, flexibly, and competently.

Even during ongoing operations, we seamlessly integrate logistics solutions into existing structures. Trust in our experience and transparency to optimize your logistics processes.

→ Our Strengths

- Specialized expertise: dedicated logistics platform design team
- Flexible design: multi-story and pre-zone platforms with AMS connection
- High-quality equipment: modular platforms, fencing, ladders, accessories
- Precise 3D planning: millimeter-accurate scans and collision checks

*Large or small
We stock it all*

→ Technical Specification

- Up to 15 m span
- Up to 3,000 kg/m²
- Up to 5 floors and more
- With/without shelving system
- Can be accessed by electric pallet trucks if required
- Powder-coated or hot-dip galvanized

→ Stored Goods

- Tools and machine components
- Vehicle parts
- Industrial machines or modular assemblies
- Temperature-sensitive goods and much more

→ Areas of Application

- Warehouses and distribution centers
- Production facilities
- E-commerce and fulfillment centers
- Retail and wholesale



→ Components



Railings

Our railings are available in a wide variety of designs.

Handrails in Sendzimir galvanized or powder-coated. In addition to our standard colors, all RAL colors are available. With or without mesh panels.



Transfer Station (with Chain)

The transfer station can be ordered in the dimensions you need. The simplicity and flexibility offer you multiple options.

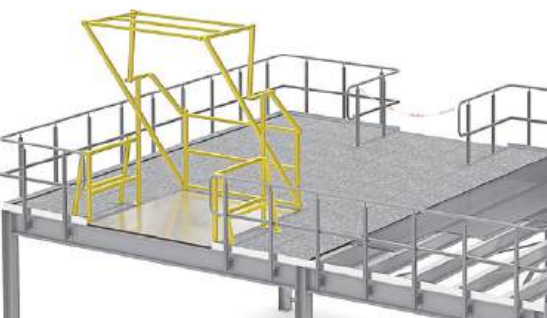

Transfer Station Security Gate

The transfer station with security gate is the safest solution to design the handover process for goods. It only allows access to the mezzanine for goods if the gate is closed.



Stairs

Would you like to use the stairs to create a small highlight or integrate them harmoniously into the overall picture? Our stairs adapt to your architecture. The steps are available in grating, checker plate, or multiplex beech on request. Railings and other steel components are available in your desired RAL color or Sendzimir galvanized.



Ladders

Our ladders are available with or without back protection.





Mezzanine Building Set

Build Your Own Platform - Modular Adaptable, Ready to Deploy

Our mezzanine building set allows you to build and extend your mezzanine based on your needs. We keep all parts in stock and can ship them within one week all over Europe. The flexibility of the design allows various shapes and designs. .

→ Technical Specifications

- Up to 4,400 mm span
- 500 kg/m²
- Passing height 2,460 mm
- Floor height 2,800 mm
- Powder-coated (uprights RAL 7012; railings RAL 7035)

→ Our Strengths

- Wide range of platform shapes possible
- Column-free design
- Available within 8 working days

→ Areas of Application

- Warehouses and workshops
- Additional storage or office spaces

→ Stored Goods

- Tools and machine components
- Offices
- Racks

→ Components



Staircase

The staircase can be mounted either directly on the platform or laterally using an intermediate landing.



Platform

With the help of the landing, the staircase can be mounted laterally on the platform.



Railings

The railing is painted in RAL 7035 light grey and is bolted directly to the platform floor.



Transfer Station (with Chain)

The width of the transfer station can be freely defined, while the depth is 1,200 mm. Other dimensions can be achieved through a customized railing configuration.

Racking Systems Overview

Versatility for Every Storage Requirement

Shelving systems maximize space utilization and ensure easy access to different storage materials. The selection ranges from cantilever racks and pallet racks to specialized systems such as stanchion racks, heavy-duty racks, and panel racks.

Thanks to their customization options, shelving systems are ideal for optimizing the storage of all types of goods – whether in small storage rooms or large industrial warehouses.

→ Solutions Available in Our Product Portfolio

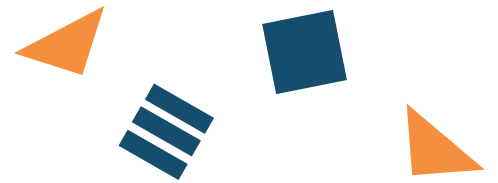

Cantilever Racks from Fischer

Mix It – Stock It – Love it

Our cantilever racks from Fischer are not afraid of any storage challenge. Indoor or outdoor.

Due to the sturdiness of their components and the large variety of add-ons, there is almost nothing that cannot be stored in them.

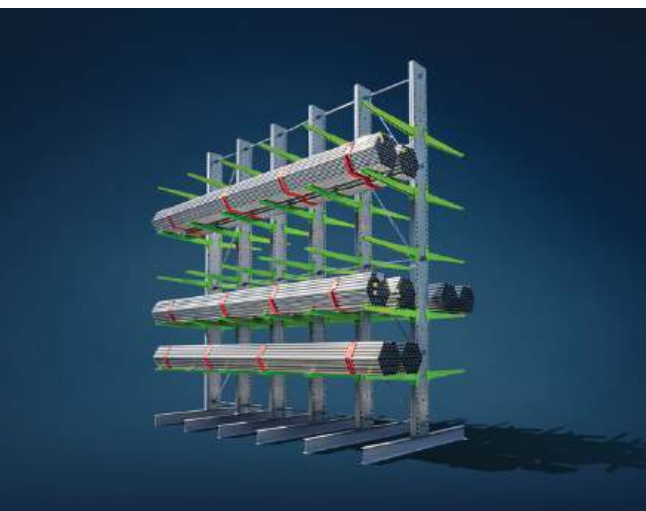

Cantilever Racking Kit

Order it - Assemble it - Use it

Our cantilever racking kit is available in different sizes and for the most frequent loads.

All parts are in stock and ready to be at your site within 10 working days.



Pallet Racks from Fischer

You Store It - We Stock It - Everywhere

The use of hot-rolled profiles results in a very robust rack that is designed for heavy challenges and challenging environments. It helps to protect your products from wind, ice, or snow.



Rung Shelves

Don't Go High - Go Low and Organize Your Stock on the Floor

Our robust rung shelves help you organize your different materials on the floor to provide perfect access for your cranes.



Heavy-Duty Racking

Too Special? Too Heavy? - Rack It

If you need to store goods that are too heavy or too large for standard racking systems, we may have the right solution. We would be happy to discuss an individual solution with you.



Record Shelves

Chipboards well organized and easily accessible

Our Record Shelf is an easily expandable solution for storing chipboards in your workshop.



Sheet Metal Shelves

For Metal Lovers and Experts

If you love steel and metal as much as we do, this rack helps you organize your material and keep it easily accessible for you and your crane.



Cantilever Racks by Fischer

Mix It - Stock It - Love It

With cantilever racking, there are no limits to your storage options! Not only are they ideal for long-goods, but with the right accessories, they also allow you to store pallets or other packaging units. No other shelving system offers so much flexibility and versatility: whether indoors or outdoors, with optional roofs, rear and side walls, or even a complete cantilever racking hall – our shelving can be adapted to suit your exact requirements.

→ Specifications

- Up to 12,000 mm height
- Up to 3,500 mm arm depth
- Up to 4,000 kg arm load
- Single-sided/double-sided
- Powder-coated paint finish or hot-dip galvanizing

→ Our Strengths

- Proven solutions for your challenges
- Extensive range of accessories
- Robust, durable product
- Designed for continuous storage

→ Stored Goods

- Wood
- Sheet metal
- Pipes
- Boxes
- Small parts
- Tools

→ Load Carries

- "Loose"
- Pallets
- Pallet cages
- Boxes/crates

→ Available Solutions:

- Small Cantilever Racks for Indoor Use
- Heavy Cantilever Racking – Hot-Rolled
- Cantilever Racks for Outdoor Use (incl. roof and walls)
- Mobile Cantilever Racks
- Cantilever Rack Halls

→ The Components of Our Hot-Rolled Cantilever Rack:



Rack Uprights for Light to Heavy Loads

The IPE upright profile made of hot-rolled steel is punched on both sides in the grid of 100 mm. Consequently, the height of the storage levels can be individually adapted to the product to be stored and the conveyor equipment used at any time. The same upright is used for single-sided and double-sided racks – this simplifies later conversion or extensions of the rack system. The upright is bolted to the base. This allows the profiles to be bundled for optimized transport.

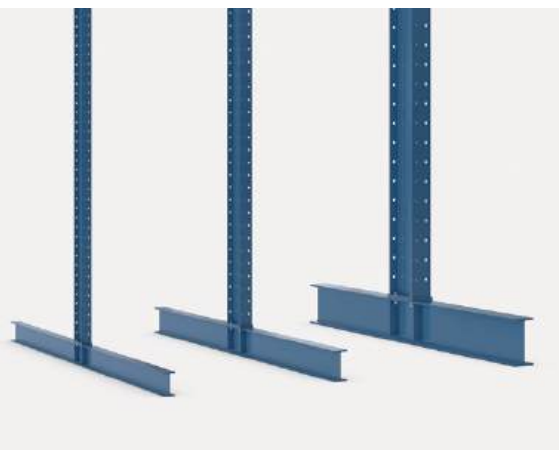

Single-Sided and Double-Sided Racks

The above-mentioned construction of the cantilever racks can be designed for single-side and/or double-sided access. The static design of the profiles is the same. The upright profiles can be manufactured with a grid perforation on both sides as an option for a later conversion to double racks, if required.



Cantilever Arms

The cantilever arms of the heavy-duty system are made of hot-rolled IPE steel profiles. Hidden rust formation is ruled out due to the solid material.

They are bolted to the vertical uprights in a 100 mm or 50 mm grid, enabling optimum design of the individual storage levels to suit the goods to be stored.

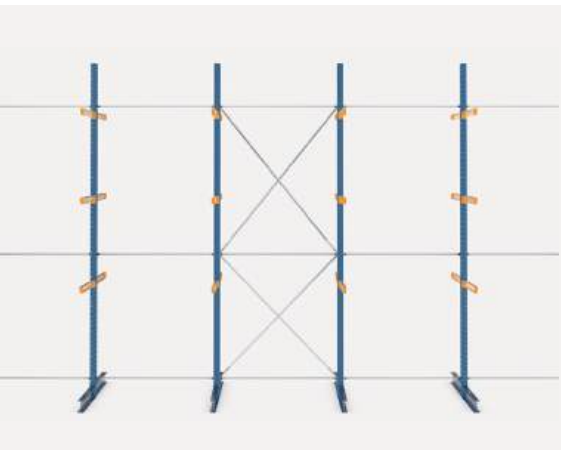

Cross Connections

The individual bays of a rack row are braced with cross connections. At the same time, they also determine the spacing between the rack uprights. This depends on the stored goods: Soft, sagging storage material is more closely supported than rigid profiles. For safety reasons, the racks should be anchored to the floor. Outdoor racks must be mounted on concrete floors or concrete bases and be secured using chemical anchors.

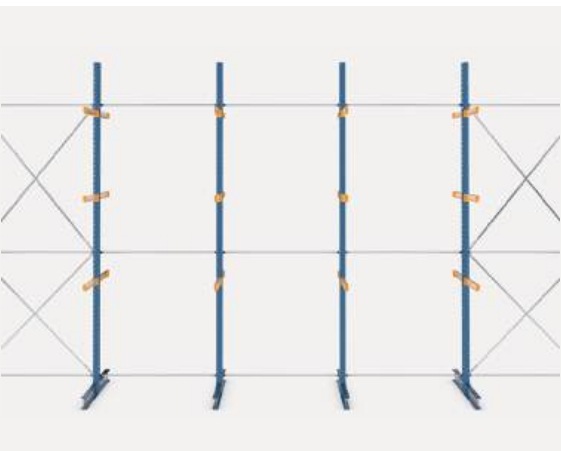

Upright Connections

Spacer tubes form the center distance between uprights, adapted to the goods to be stored. Cross braces additionally reinforce the rack.



Arm Bridge

The arm bridge connects the cantilever arms horizontally and enables the storage of pallets.

This creates a continuous storage level without interfering intermediate supports – this provides maximum flexibility for storage of different pallet formats.



Foot Bridge

The foot bridge connects the upright feet horizontally and, in this way, already enables the storage of pallets on the lowest level of the cantilever rack.

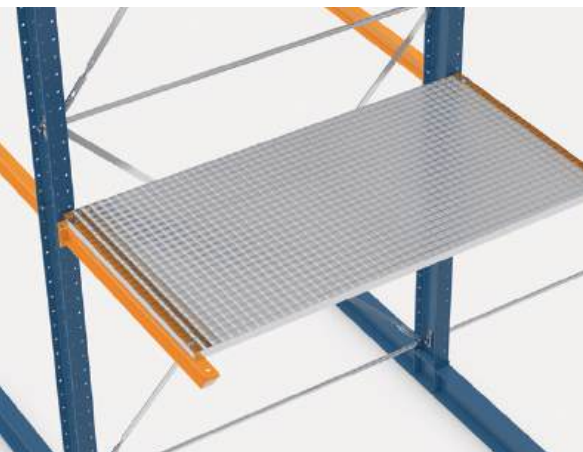

Grating Shelves

Shelves placed on cantilever arms allow the mixed storage of unpacked goods or goods without loading aids, cartons, etc. As there are no intermediate supports, flexible storage is possible along the entire length of the rack row. Grating shelves can accommodate high point loads and can also be used as shelf supports in sprinkler systems.



Chipboard Shelves

Chipboard shelves are primarily used in the order picking area as well as for the storage of pallets, cartons, and boxes.

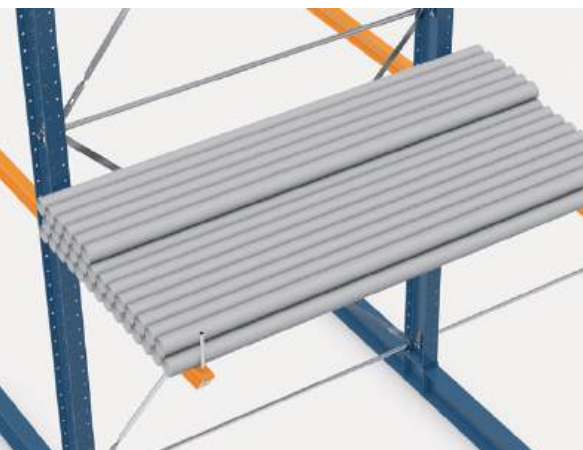

Anti-Rolling Protection

To prevent round material from falling out of the cantilever rack, bolts are fitted to the ends of the cantilever arms as anti-rolling protection.



Guide Rails

When using narrow-aisle forklifts and automated storage and retrieval systems, it is recommended to protect the bases of the cantilever racks from collision damage by using guide rails.

At the same time, they make maneuvering in narrow aisles easier.

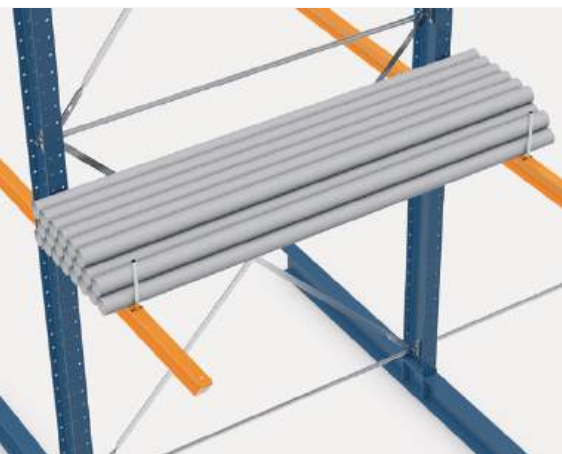

Compartment Dividers

The storage levels can be further subdivided by compartment dividers so that different long- goods can be stored on one level. The system for light and medium loads has a perforation in the center of the cantilever arms into which the compartment divider is inserted and bolted. In the case of the heavy-duty cantilever racks, the compartment dividers can be moved continuously on the L-profile of the cantilever arms.



Outdoor Use

We provide cantilever rack systems in a high-quality, durable hot-dip galvanized version according to DIN EN ISO 1461 for outdoor use.

In addition, the stored goods can be protected from weather conditions by mounting roof and wall elements on the cantilever racks.

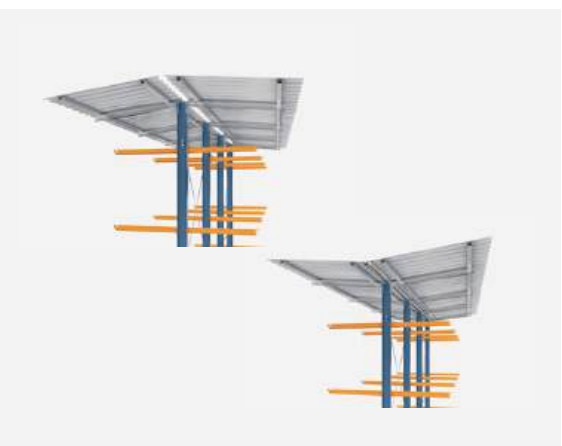

Roof Elements

To protect the goods from weather conditions, cantilever racks can be equipped with various roof options. Two alternatives are available: special roof arms mounted on the top of the uprights that support roof elements made of trapezoidal sheet metal, or the rack uprights can directly support a complete roof structure, for example made of wood (typically installed by a local contractor or by the customer). Drainage systems and downpipes are also available.



Wall Elements

If required, additional protection against weather conditions can be provided by rear and side walls made of trapezoidal sheet metal.

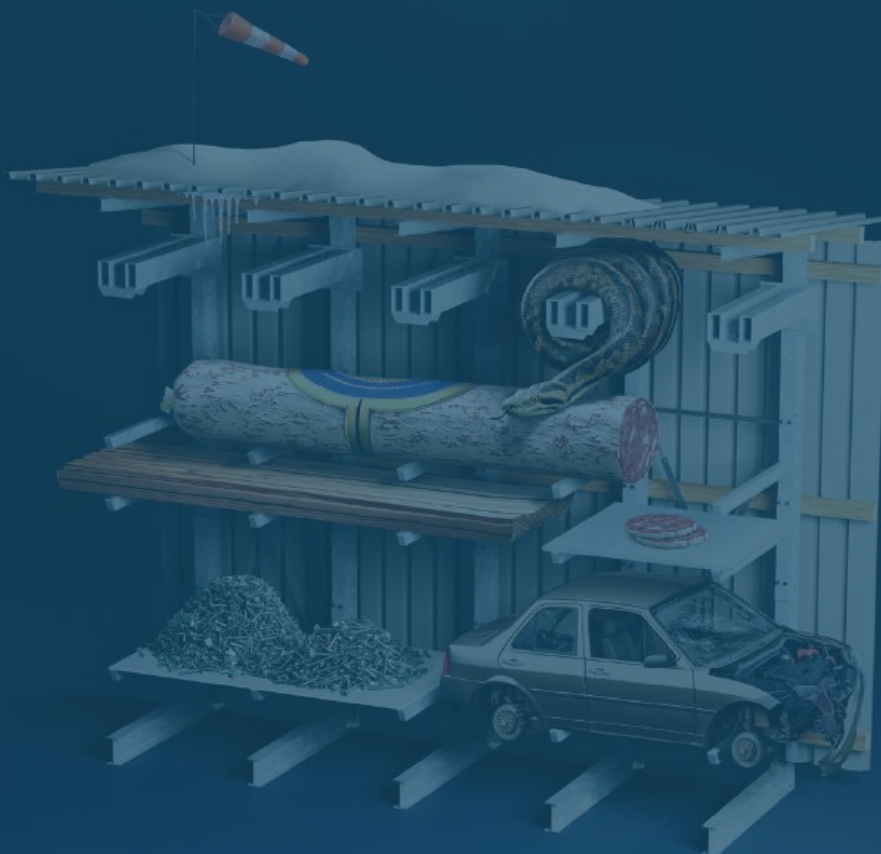



Small Cantilever Racks for Indoor Use

With cantilever racks from FISCHER, there are no limits! Not only can you store long goods on them, but with the appropriate accessories, you can also store pallets or other packaging units. No racking system is more versatile than a cantilever rack. The racks can be used both indoors and outdoors, e.g., with a roof/back wall/side wall, right up to a cantilever rack hall.

→ Specifications

- Up to 5,000 mm height
- Up to 1,500 mm arm depth
- Up to 1,500 kg arm load
- Single-sided/double-sided
- Christmas tree design (for crane operation)
- Angled cantilever arm
- Powder-coated paint finish or hot-dip galvanizing

→ Our Strengths

- Proven solutions for your challenges
- Extensive range of accessories
- Robust, durable product
- Designed for continuous storage

→ Stored Goods

- Wood
- Sheet metal
- Pipes
- Boxes
- Small parts
- Tools

→ Load Carriers

- “Loose”
- Pallets
- Pallet cages
- Boxes/crates

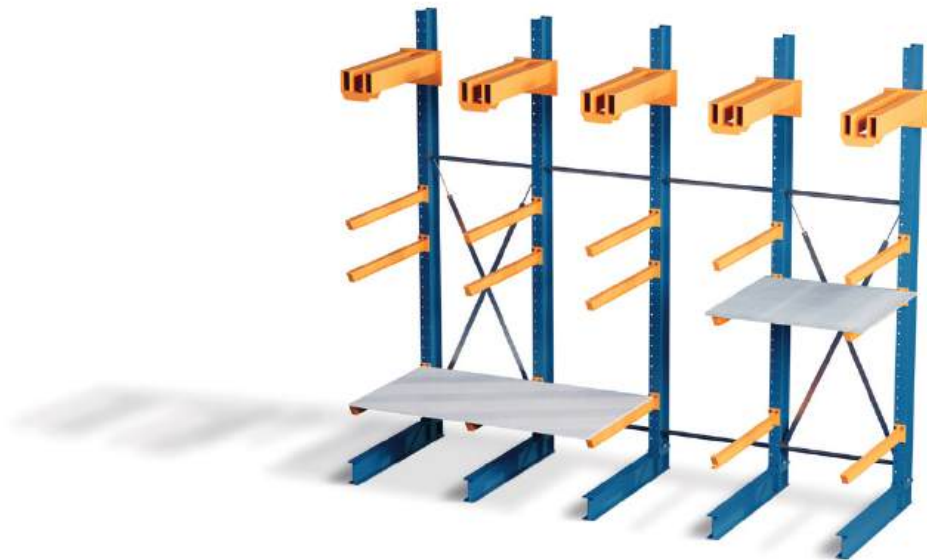

Heavy Cantilever Racking – Hot-Rolled

Our heavy-duty cantilever racks – hot-rolled – are ideal for storing a wide variety of goods. Thanks to different cantilever designs and a large selection of shelf coverings, they offer flexible solutions for almost any requirement.

→ Specifications

- Up to 12,000 mm height
- Up to 3,500 mm arm depth
- Up to 4,000 kg arm load
- Single-sided/double-sided
- Powder-coated paint finish or hot-dip galvanizing

→ Our Strengths

- Proven solutions for your challenges
- Extensive range of accessories
- Robust, durable product
- Designed for continuous storage

→ Stored Goods

- Wood
- Sheet metal
- Pipes
- Boxes
- Small parts
- Tools

→ Load Carriers

- “Loose”
- Pallets
- Pallet cages
- Boxes/crates



Cantilever Racks for Outdoor Use

Our hot-rolled cantilever racks can handle any challenge – from snow, wind, and rain to desert sand and salt water. With customized roofs, they protect your stored goods reliably and safely in all conditions.

For outdoor use, we offer cantilever racking systems in a high-quality and durable hot-dip galvanized design in accordance with DIN EN ISO 1461. In addition, stored items can be protected from weather conditions by mounting roof and wall elements on the cantilever racks.

→ Specifications

- Up to 12,000 mm height
- Up to 3,500 mm arm depth
- Up to 4,000 kg arm load
- Single-sided/double-sided
- Hot-dip galvanizing

→ Our Strengths

- Proven solutions for your challenges
- Extensive range of accessories
- Robust, durable product
- Designed for continuous storage

→ Stored Goods

- Pipes and sheets
- Stones and wood packages
- Coils or heavy long goods pallets
- Car wrecks and much more

→ Load Carries

- “Loose”
- Pallets
- Pallet cages
- Boxes/crates

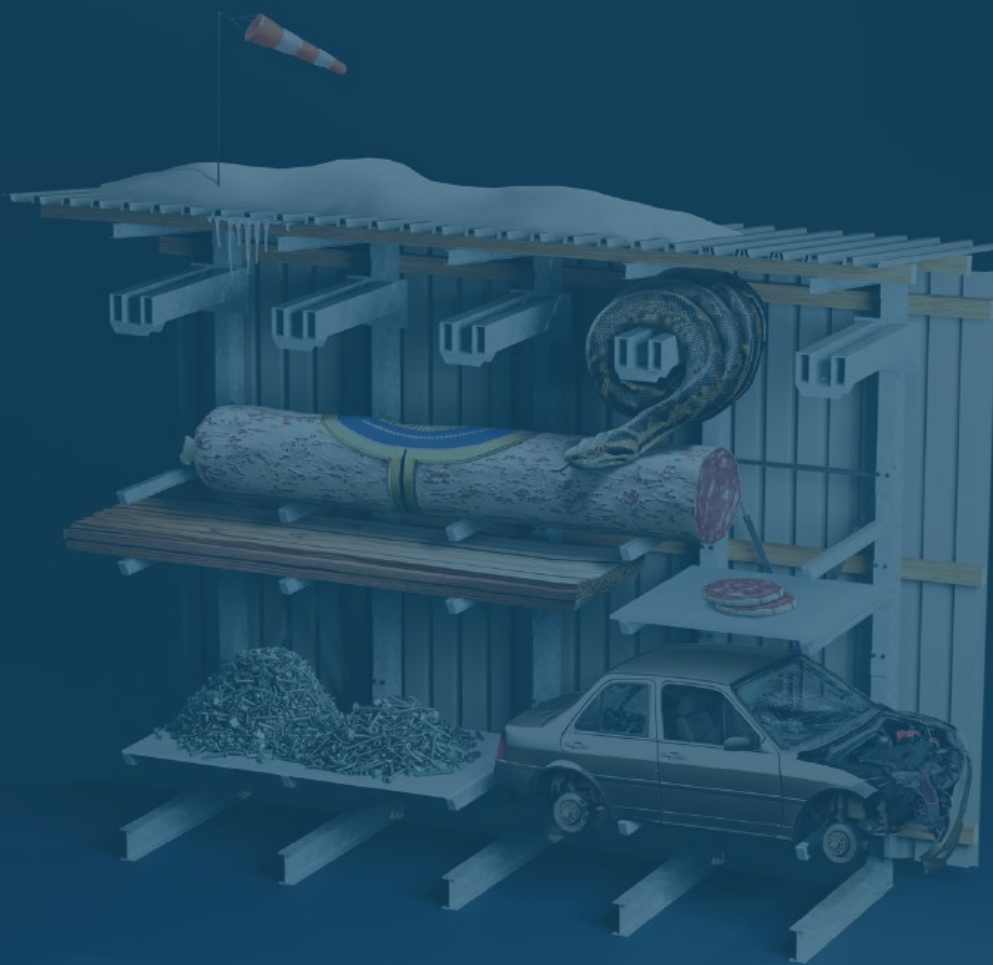

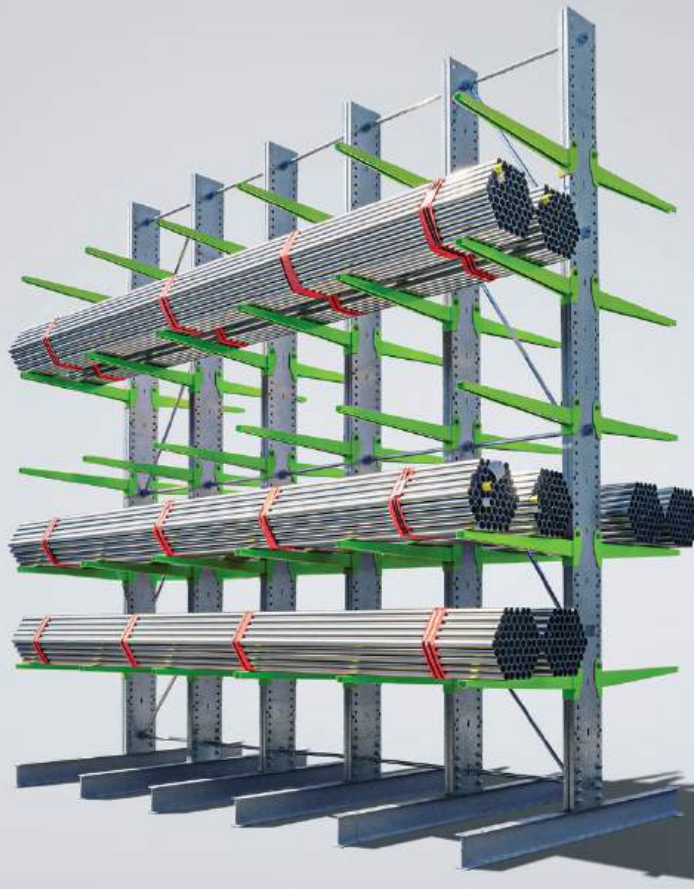

Cantilever Racking Kit

The Fast and Practical Solution for Standard Storage Needs

The cantilever rack kit from RR Fischer is the quick and practical solution to your storage problem. Although not as versatile as our standard rack, it is easy to configure and can usually be delivered to your site within two weeks.

All levels can be delivered anywhere in Europe within two weeks.

→ Our Strengths

- Cost-effective product
- Fast availability
- Flexible product (easy to convert, expandable)

→ Areas of Application

- Can be used in all areas
- From single-type storage to mixed storage
- All load carriers, all lengths

→ Stored Goods

- Building materials
- Pipes, sheet metal
- “Almost everything”



→ Technical Specifications

- Available heights: 4,100 mm; 4,400 mm; 4,800 mm; 5,200 mm; 5,600 mm; 6,000 mm; 6,300 mm
- Available cantilever lengths: 800 mm (660 kg); 1,000 mm (850 kg); 1,250 mm (800 kg); 1,250 mm (1,000 kg); 1,500 mm (600 kg)
- Center distance: 1,000 mm; 1,250 mm; 1,500 mm
- Single-sided or double-sided
- With or without roof
- Indoor or outdoor use
- Single-sided or double-sided design
- Stand: galvanized
- Base: hot-dip galvanized
- Arm: powder-coated (summer green)



→ Components:



Cantilever Column

- Load-bearing steel profiles made of quality steel with parallel profiles
- Parallel uprights simplify storage/retrieval
- Arms adjustable in 76 mm increments optimize the height division of the shelves
- Double-sided column punching allows for a change to double-sided use in the future
- All components are screwed or plugged in, which facilitates future conversion and expansion.
- 3 grades of uprights, available in 21 standard heights and payloads up to 6,000 kg. Available Payloads:

4,100 mm	4,400 mm	4,800 mm	5,200 mm	5,600 mm	6,000 mm	6,300 mm
----------	----------	----------	----------	----------	----------	----------



Column Base

- Base made of robust, hot-rolled structural steel IPE sections
- Due to the solid design, it is resistant even to forklift impacts
- The standard hot-dip galvanization prevents corrosion, especially in the case of waterlogging
- Single / double-sided bases available in 10 versions



Cantilever Arms

- Tapered cantilever arm design optimizes the shelf heights
- The arms are connected to the column without tools via a plug-in bolt system
- Huge advantage: the arms have a flexible connection and move with impacts from goods or forklifts
- Very simple, tool-free adjustment of the cantilever arms possible
- Powder coating in exterior quality finish and resilient against mechanical impacts



Column Bracings

- Center distances are available in three dimensions: 1,000 mm, 1,250 mm, 1,500 mm

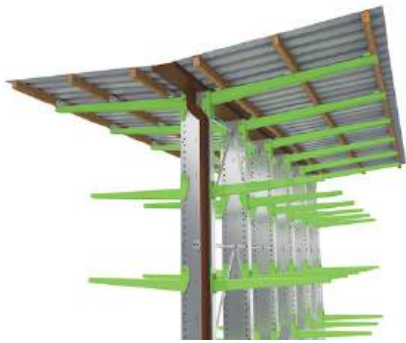

Roof Canopy

- The roof consists of roof sheeting, purlins, guttering and canopy support arms
- The roof canopy arms are mounted securely and wind-resistant on the cantilever columns with push-in bolts
- The purlins and the roof sheeting are square timber and trapezoidal sheeting provided by the customer

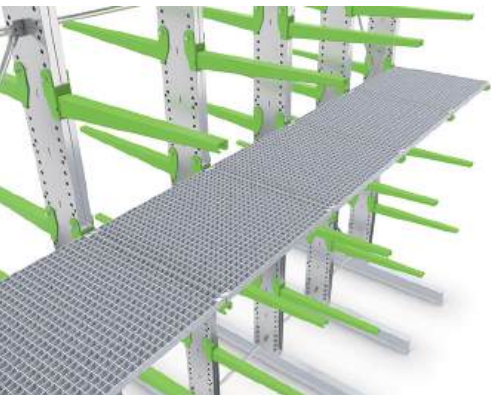

Shelf Gratings

- Gratings create a continuous storage level without interfering intermediate uprights
- Pallets, wire mesh boxes, goods carriers with/without overhang of all dimensions can be stored without loss of space
- The gratings are placed on the cantilever arms and bolted with clamping brackets
- Retrofitting with gratings is possible at any time





Pallet Racking by Fischer

You Store It – We Stock It – Everywhere – Pallet Racking by Fischer

Our pallet racking systems offer flexible and versatile solutions for a wide range of storage requirements. Our focus is on particularly robust systems made from hot-rolled, hot-dip galvanized structural steel, specifically designed for outdoor use or harsh workshop environments.

Our hot-rolled pallet racks easily master even the most demanding requirements. Extreme bay loads and large spans are not a challenge – they are standard.

→ Our Strengths

- Individually designed and manufactured to your needs
- Customized solutions tailored to your geographic location
- Extensive range of accessories
- Robust, durable products

→ Technical Specifications

- Height up to 9 m
- Bay depth up to 2.5 m
- Loads up to 15 t per storage position
- Powder-coated or hot-dip galvanized

→ Applications

- Single- or multi-position storage
- Indoor or outdoor installation
- Rack-supported halls
- Drive-in or drive-through racking

→ Stored Goods

- Building materials
- Construction materials
- Tool components

→ Accessories



Roof and Side Walls

Would you like to install your rack system outdoors and protect your goods from the weather?

Our trapezoidal sheet metal roofs, rear and side walls provide optimal protection against snow, wind, and rain.



Barrel Supports:

With our barrel supports you can easily store barrels, cable coils, or any other round storage goods. If you need specific storage solutions within the pallet rack, please reach out to us. Due to the high stability of our pallet rack, almost nothing is impossible.





Rung Shelves

Don't Go High – Go Low and Organize Your Stock on the Floor

Rung shelves are versatile storage systems characterized by flexible design and high stability. They consist of horizontal posts mounted on vertical uprights and are ideal for storing bulky goods such as pipes, timber or metal profiles. Their modular design allows easy adaptation to individual requirements, making them suitable for both industrial and craft applications.

→ Our Strengths

- Custom-made
- Robust
- Flexible

→ Load Carriers

- Loose items
- Bundles

→ Technical Specifications

- Post height up to 3,000 mm
- Bay loads up to 5,000 kg
- Post pitch 50 or 100 mm
- Powder-coated or hot-dip galvanized

→ Stored Goods

- Pipes
- Bars
- Long profiles
- Panels



Heavy Duty Racking Solutions Developed by Fischer

Too Special? Too Heavy? – Rack It

Our heavy-duty racking systems are the perfect solution for demanding storage applications where conventional pallet racks reach their limits. With exceptional load-bearing capacity and robust construction, they safely support extreme bay loads while covering large spans.

This makes them ideal for industries requiring the storage of heavy, bulky or awkward goods.

Whether in industrial production, mechanical engineering or the storage of large-format tools and heavy machine components – our heavy-duty racks guarantee stability and safety. Custom-designed solutions allow adaptation to specific requirements, such as variable shelf heights, additional reinforcements or special supports for sensitive or oversized items.

→ Our Strengths

- Individually designed and manufactured
- Robust, durable products
- Modular design

→ Technical Specifications

- Height up to 5,000 mm
- Bay width up to 2,700 mm
- Bay load up to 15 t
- Powder-coated or hot-dip galvanized



Record Shelves

Record Shelves are the ideal solution for safely and space-efficiently storing large, flat materials such as wooden panels, sheet metal, plastic boards or glass. Designed specifically for industrial, trade and construction applications, they offer robust construction, high load capacity and flexible customization options.

→ Our Strengths

- Robust construction made of high-quality square tubing
- Optional rollers in front of each bay for effortless loading and unloading
- Modular design for flexible expansion
- Quick and easy assembly
- Durable powder coating for optimal protection
- Optional usable roof level as additional storage space

→ Technical Specifications

- Rack depths: 2,500 / 3,000 / 4,000 / 5,000 mm
- Clear bay height: 2,200 mm
- Clear bay width: 400 mm
- Finish: Pure White RAL 9010
- Includes roller on one side



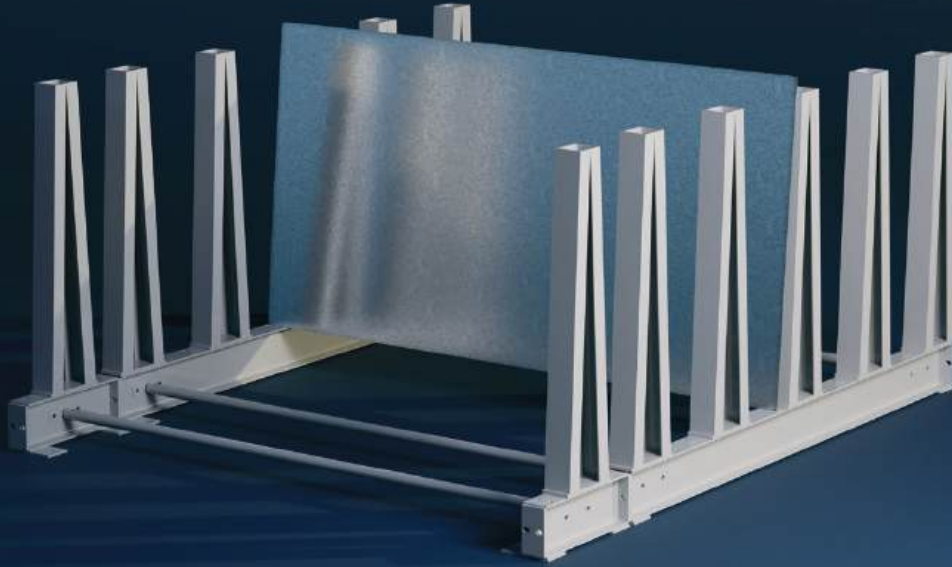

Sheet Metal Shelves

Our sheet metal shelv is designed to help you keep your metal sheets sorted and organized while having them easily available at any time. The design supports crane access as well.

→ Our Strengths

- Robust construction made of high-quality steel profiles
- Modular design for flexible expansion
- Quick and easy assembly
- Durable powder coating for optimal protection
- Optional usable roof level as additional storage space

→ Technical Specifications

- Rack width: 1,800 mm / 2,300 mm / 2,800 mm
- Base version 4 slots
- Extension in 1-slot steps

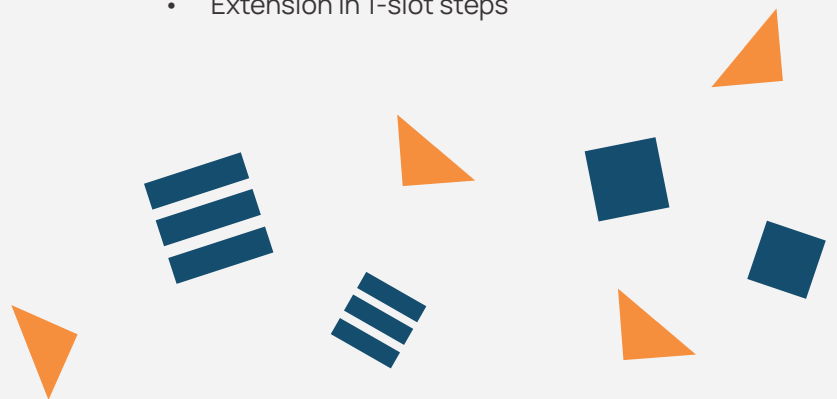

Dynamic Storage Systems

Add Motion to Your Warehouse

Our dynamic storage systems adapt to your challenges – regardless of size, weight or application. From lightweight cartons and plastic containers to heavy pallets made of wood, plastic or metal, we offer the right solution.

FIFO or LIFO, consumer goods, food, automotive parts or building materials – our intelligent technology keeps your warehouse moving.

→ Solutions Available in Our Product Portfolio



Pallet Conveyors by Rack & Roll

You Store It – We Roll It

Pallet roller conveyors from Rack & Roll maximize your pallet spaces and optimize the availability of goods in your warehouse. They enable quick and easy storage and retrieval – reliably and efficiently, even at extreme temperatures from -30 °C to +50 °C. Whether metal, plastic, half or special pallets: everything gets rolling with us.



Pushback Trolley System by AQS

Don't Worry – Just LIFO It

The AQS Pushback Trolley is the ideal solution for transverse storage of pallets using the LIFO principle.

It easily handles a wide variety of pallet types and impresses with its skid support, which ensures maximum flexibility and efficiency regardless of the pallet quality.

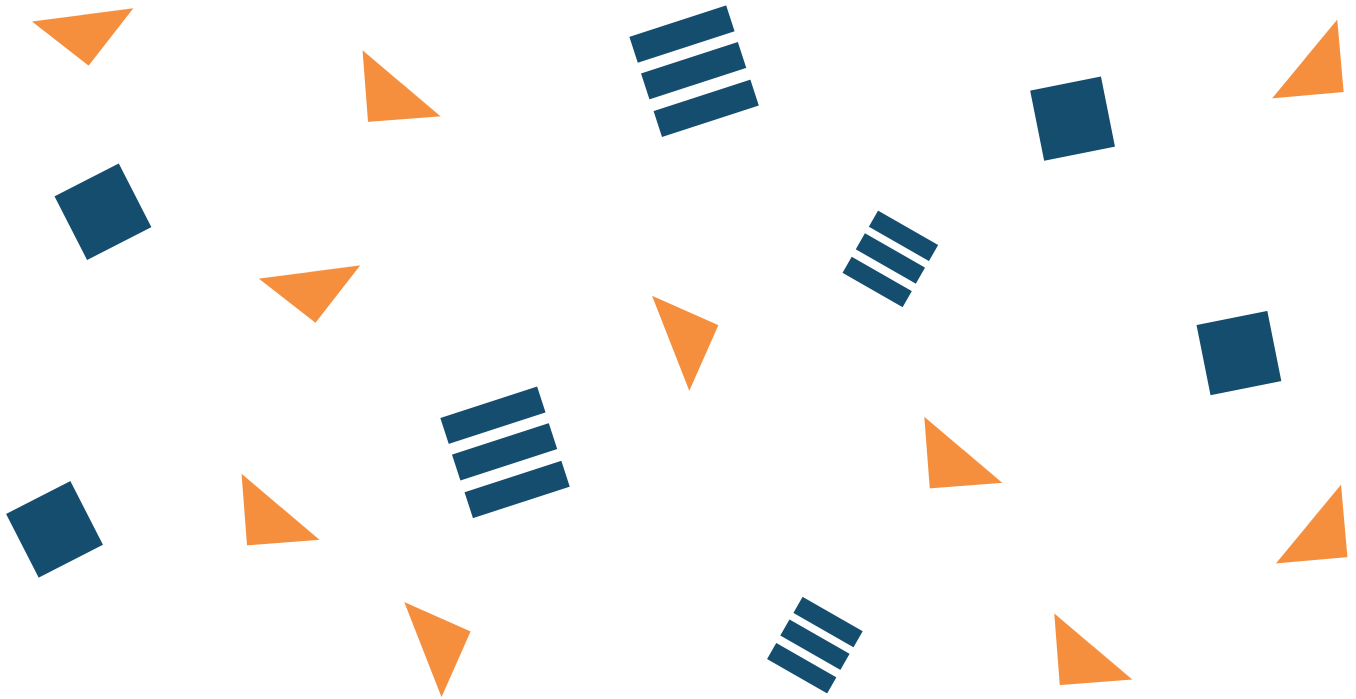

XXL Conveyors by AQS

They Say It Can't Be Rolled – We Let It Roll

When others claim it can't be rolled, we get it rolling in a controlled manner. No base geometry is too complex for us, no load carrier too heavy.

AQS XXL roller tracks are the dynamic counterpart to our hot-rolled racking – robust, indestructible and ready for any challenge.



Carton Flow Systems by AQS

Because Size Matters – From S to XL

Our container conveyor technology ensures efficient and ergonomic handling in warehouses and production facilities.

Increase productivity and optimize your work processes – from light cardboard boxes to heavy containers – we get them rolling in a controlled manner.



Pallet Conveyors by Rack & Roll

You Store It – We Roll It

From pallet roller tracks and push-back trolleys to XXL roller rail systems, we provide the right technology for efficient storage and retrieval – across all temperature ranges and for every pallet type.

Our Solutions – Pallet Roller Tracks

Rack & Roll pallet roller tracks maximize pallet storage positions and improve product availability in your warehouse. They enable fast and easy infeed and outfeed – reliable and efficient, even at extreme temperatures from -30 °C to +50 °C.

Whether metal, plastic, half-size or special pallets: with us, everything keeps moving.

→ Our Strengths

- Individually tailored solutions – perfectly matched to your requirements
- Ability to combine different pallet weights within the same lane
- Roller tracks for AGV loading and unloading

→ Technical Specifications

- Flow depth up to 40 m
- Load per load carrier 80–1,500 kg
- Transverse and longitudinal transport
- Compatible with all standard pallet racking systems
- FIFO or LIFO storage

→ Applications

- FIFO or LIFO storage
- Dispatch staging lanes
- Picking lanes
- Supermarket principle

→ Stored Goods

- Food products
- Consumer goods
- Automotive parts

→ Accessories



Pallet Separators

Do you want to discharge your goods in a controlled way, without back pressure?

Our mechanical and pneumatic separators ensure that exactly one pallet is always safely presented. After removal, the next pallet automatically rolls into the pick position – or you can unlock the separator manually by hand or foot, exactly when you need it. Even mixed operation with different pallet types on the same roller track is easily possible, ensuring maximum flexibility.



Pallet Guidance

Do you want your pallet to be guided precisely on the roller track and presented at a defined end point – for example for AGV pick-up?

Whether insertion funnels, side guide profiles or guide rollers – we have the right solution for your application.



Infeed / Outfeed Modules

Do you operate different industrial trucks in your warehouse?

Based on your operating concept, we supply the infeed and outfeed side in one-piece, two-piece or three-piece versions.

With or without entry plates – exactly as you require.

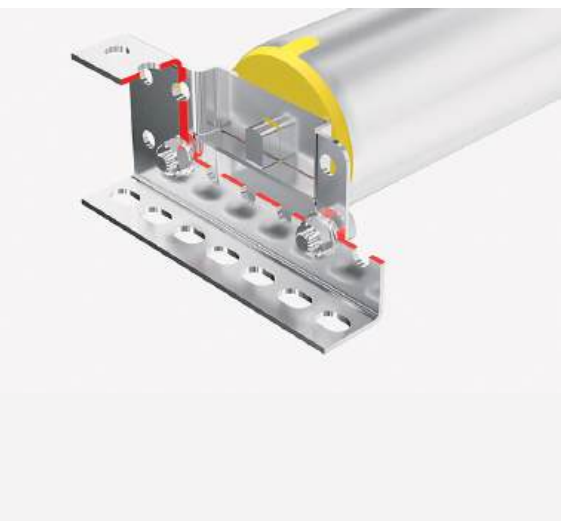

Brake Load Rollers

Speed isn't everything – controlled, smooth pallet travel is what matters.

With our extensive range of brake load rollers, we can respond flexibly to your individual requirements.

We ensure pallets roll evenly and are safely braked and presented – for maximum efficiency and safety in your warehouse.



Foldable Lanes

Do you want to clean the area beneath the floor-level roller track quickly and easily?

Our floor-level roller tracks are also available as a practical foldable module. Assisted by pneumatic spring support, folding up and down is effortless – giving you fast, easy access for cleaning at any time.

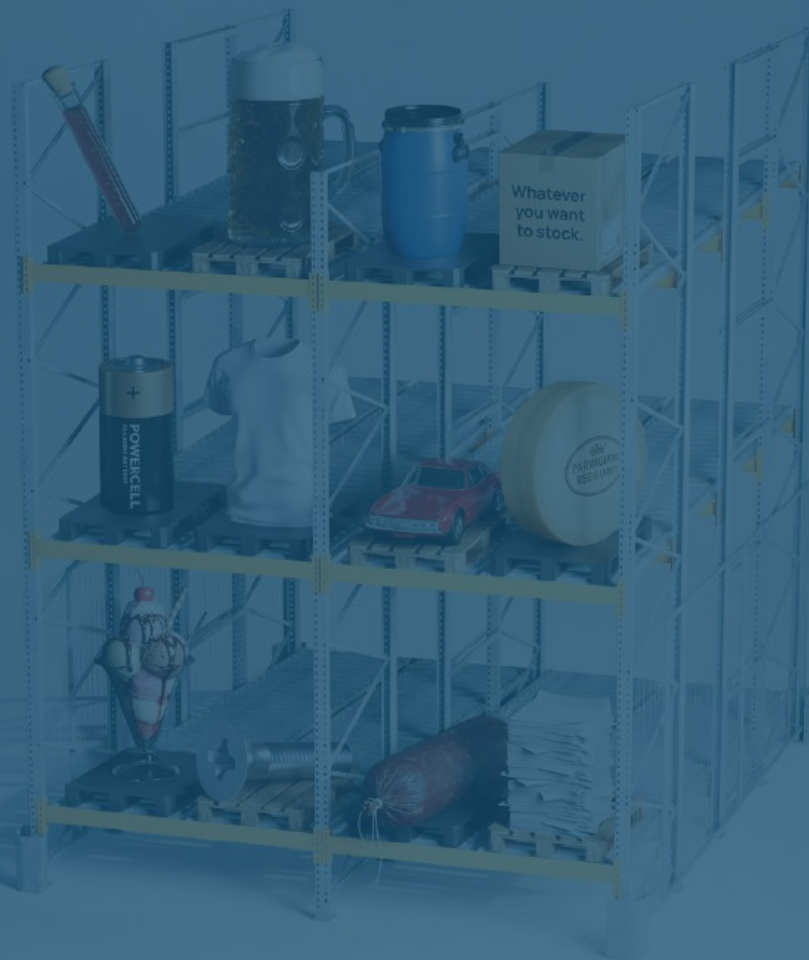



Pushback Trolley System by AQS

Don't Worry – Just LIFO It

The “Pushback Trolley System” is an economical, technically sophisticated alternative to classic roller tracks – ideal for cross-stored pallets according to the LIFO principle. It can be integrated into existing pallet racks at any time, including in cold storage.

Retrofitting drive-in racks is particularly attractive, as the time-consuming driving into lanes is eliminated. Instead, the system enables simple, safe and flexible storage, allowing different products to be stored on each level.

→ Our Strengths

- Independent of pallet quality
- Infeed and outfeed without back pressure
- Operation possible without mast tilt
- No contact with the goods

→ Technical Specifications

- 3-6 pallet positions
- Load per load carrier 80-1,500 kg
- Transverse or longitudinal transport
- Compatible with all standard pallet racking systems
- Horizontal or non-horizontal pallet storage surface
- LIFO storage

→ Stored Goods

- Food products
- Consumer goods
- Secondary packaging

→ Applications

- LIFO storage

→ Explanation

- Runner support
- Hat profile
- Fill level indicator
- End stop
- Trolley
- Floor bracket





XXL Conveyors by AQS

They Say It Can't Be Rolled – We Let It Roll

When others say it can't be rolled, we make it roll – in a controlled way. No base geometry is too challenging, and no large load carrier (LLC) is too heavy for us. AQS XXL roller rails are the dynamic counterpart to our hot-rolled racks – virtually indestructible and ready for any challenge.

→ Our Strengths

- Excellent tracking accuracy, even over long flow depths
- Flexible for a wide range of base geometries
- Loads up to 3 t per storage position possible
- Up to 14 pallet types can be stored in the same lane

→ Applications

- FIFO or LIFO storage
- Supermarket principle

→ Technical Specifications

- Flow depth up to 30 m
- Load per load carrier 15–3,000 kg
- Transverse or longitudinal transport
- Compatible with all standard pallet racking systems
- FIFO or LIFO storage

→ Stored Goods

- Building materials and batteries
- Cast parts in body-in-white production
- Aircraft containers
- Heat pumps

→ Technical Specifications

- Transport starting from 55 mm Ø disc base
- Transport of large load carriers (with disc bases / runners)
- Universal transport for various pallet types
- Operating range from 15 kg to 3,000 kg
- Transport of stacked load carriers
- Wide weight range 15 kg-1,500 kg per linear meter
- Reduced wear of load rollers thanks to ball bearings
- Low-friction performance with high throughput rates
- Manual shifting possible: 0% slope
- Change of travel direction transverse/longitudinal at workstations
- Back-pressure-free pallet discharge, manual/electric
- Slope from 0% to 4% possible
- Wet or humid areas

→ Accessories



Pallet Separators

Do you want to discharge goods in a controlled way and without back pressure? Our mechanical or pneumatic separators ensure that exactly one pallet is safely presented at all times. Depending on your requirements, you release it by hand, foot or via “dragging” removal. Mixed pallet operation is also possible.



Pallet Guidance

Do you want your pallet to be guided precisely on the roller track and presented at a defined end point – for example for AGV pick-up?

Whether insertion guides, side guides or guide rollers, we have the right solution for your needs.

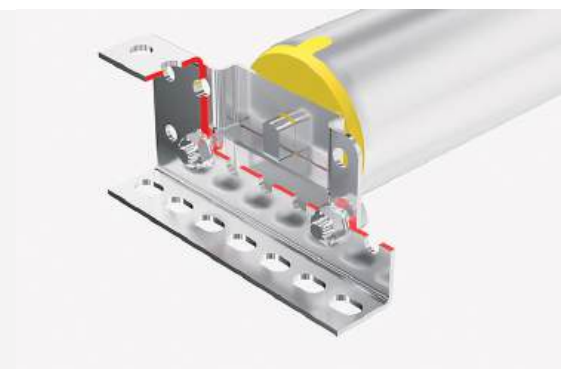

Brake Load Rollers

Faster isn't always better – but letting go should still be effortless.

With our broad portfolio of brake rollers, we can respond flexibly to your challenges and ensure pallets roll evenly and are presented reliably and safely.



Carton Flow Systems by AQS

Because Size Matters – From S to XL

Our container flow technology ensures efficient, ergonomic handling in warehouses and production facilities. Increase productivity and streamline your processes – from lightweight cartons to heavy-duty totes, we keep everything moving in a controlled way.

To supply you with the most cost-efficient product, we have developed four different solutions. From S (material minimized) to XL, providing solutions for high load demands.

Accessories for Flow Levels (S to XL)

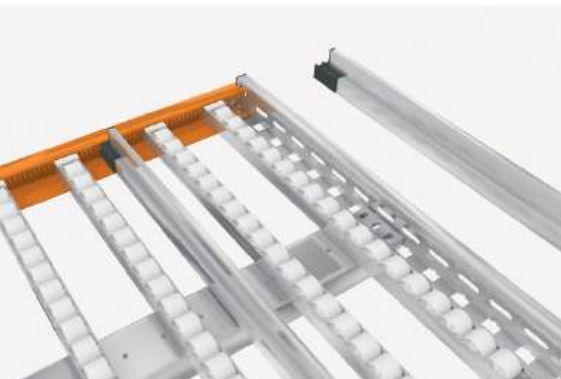

Guide Rails for Channel Separation

Do you want to use the channels on one level flexibly and separate your load carriers from each other?

Our guide rails can be adjusted without tools. They ensure each container stays in its lane.

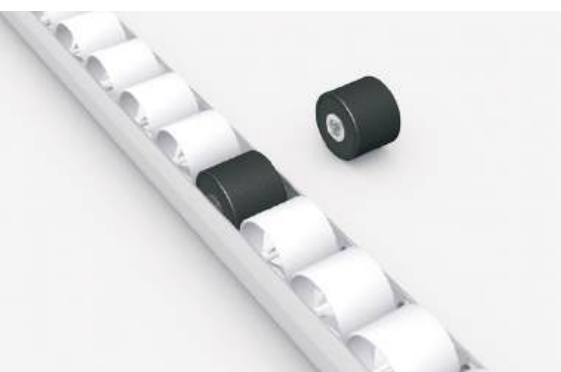

Braking Technology by AQS

Do you want your containers not just to roll, but to roll smoothly, evenly and come to a stop exactly where they should?

Whether brake rollers with planetary gearing or classic brake bars – we know how to keep gravity under control.

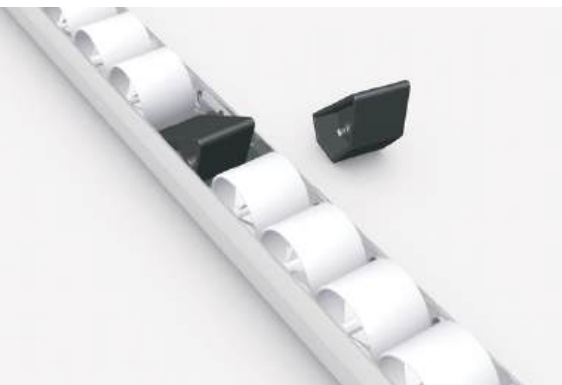

Mechanical Backstop / Roll-Back Protection

Are you combining people and machines, or do you want to prevent anything from dropping out at the rear?

Our mechanical backstop helps you do exactly that. It can be installed easily in place of an existing roller and can be retrofitted at any time.



End Stop with Run-Up Ramp

Do you want to make sure your goods don't overshoot the target?

Our end stop reliably decelerates the goods and ensures they are ready for picking at the end of the lane. It can be retrofitted at any time into the roller track profile.



Order Picking Shelves

Do you want to maintain a clear overview and make life as easy as possible for your pickers?

Our picking shelves are available with different inclinations (6°, 15° and 21°) and discharge depths of 300 and 400 mm.



Scanner Rail / Pick-by-Light

Would you like to make picking easier and support your team with modern technology?

We are happy to prepare the levels individually so you can mount a pick-by-light system of your choice.

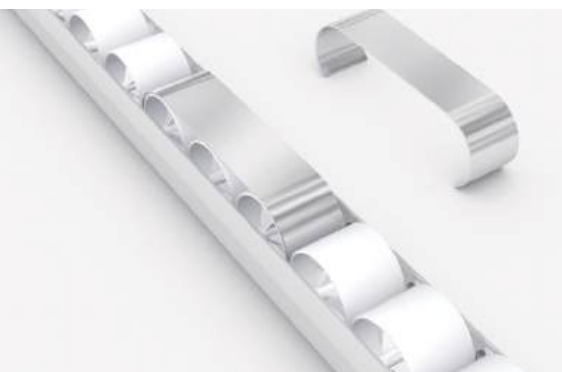

Brake Brackets

In order to reduce the speed of the boxes, you can easily add brake brackets to the roller track.



Handrails

To make it easier for users to access higher levels, we can provide you with handrails mounted on the front beam of our carton flow level.



Steps

To make it easier for users to access higher levels, we can provide you with footsteps mounted in front of the rack.



Racking System (AQS Flex)

Instead of mounting the levels into an existing pallet rack (any producer), we can provide you with independent racking up to a height of 3,000 mm.



Conveyor Technology Bracket

If required, we can provide you with additional rollers in front of the rack. Alternatively, you can also install driven conveyors on top of our rack.





Carton Flow Level System S

With a bay width of up to 1,800 mm and a maximum load of 75 kg per square meter, this flow level is purpose-built for the efficient storage of light containers. It supports both FIFO and LIFO. Learn more!

The Flow Roller Level S is the cost-optimized solution for efficient warehousing: with its own rack framework, integrated Speed Control and versatile loading and unloading options – whether manual, via AMS, shuttle or AGV – it delivers maximum flexibility.

→ Our Strengths

- Cost-optimized
- Includes its own rack framework
- Includes Speed Control
- Loading and unloading manually, via AMS, shuttle or AGV

→ Technical Specifications

- Bay width up to 1,800 mm
- Flow depth up to 4,000 mm
- Load per m² up to 75 kg
- ESD- and cold-store suitable

→ Load Carries

- Cartons
- Plastic containers
- Crate trays
- Blister packs

→ Stored Goods

- Consumer goods
- Components
- Spare parts



Carton Flow Level System M

With a bay width of up to 2,800 mm, an impressive flow depth of up to 20,000 mm and a load capacity of up to 170 kg per square meter, the Flow Roller Level M is suitable for ESD and cold-store applications.

→ Our Strengths

- Flexible
- Slope can be adjusted/changed flexibly
- Includes its own rack framework
- Includes Speed Control
- Loading and unloading manually, via AMS, shuttle or AGV

→ Technical Specifications

- Bay width up to 2,800 mm
- Flow depth up to 20,000 mm
- Load per m² up to 170 kg
- ESD- and cold-store suitable

→ Load Carries

- Cartons
- Plastic containers
- Crate trays
- Blister packs

→ Stored Goods

- Consumer goods
- Components
- Spare parts



Carton Flow Level System L

Our L level is particularly well suited for integration into racking with a bay width of up to 3,800 mm. It was developed specifically for large spans and the storage of light loads, delivering maximum stability and efficiency.

→ Our Strengths

- Variable
- Slope can be adjusted as required
- Equipped with its own rack framework
- Includes Speed Control
- Loading and unloading manually, via AMS or AGV

→ Technical Specifications

- Bay width up to 3,800 mm
- Flow depth up to 6,000 mm
- Load per m² up to 125 kg
- ESD- and cold-store suitable

→ Load Carries

- Cartons
- Plastic containers
- Crate trays
- Blister packs

→ Stored Goods

- Consumer goods
- Components
- Spare parts



Carton Flow Level System XL

Our XL level is the ideal solution for everything that is too large, too wide or too heavy for other systems. It handles virtually any challenge in container flow applications and impresses with a load capacity of up to 300 kg per square meter at a bay width of 3,800 mm – powerful, reliable and versatile.

→ Our Strengths

- Flexible
- Slope can be adjusted/changed flexibly
- Includes its own rack framework
- Includes Speed Control
- Loading and unloading manually, via AMS, shuttle or AGV

→ Technical Specifications

- Bay width up to 3,800 mm
- Flow depth up to 6,000 mm
- Load per m² up to 300 kg
- ESD- and cold-store suitable

→ Load Carries

- Cartons
- Plastic containers
- Crate trays
- Blister packs

→ Stored Goods

- Consumer goods
- Components
- Spare parts

Your Strong Partner

Expertise You Can Rely On

Our products are designed to provide planning reliability and marketing confidence for dealers and resellers. Whether as a standalone solution or as part of a complete project, we deliver robust systems, clear technical data and a partnership based on mutual trust.

Your Advantages as a Sales Partner

- Manufacturer expertise with high vertical integration
- Project support from initial planning through implementation
- Custom designs instead of off-the-shelf solutions
- Technically sound systems for tenders
- Reliable delivery and project timelines
- Europe-wide project experience



We are happy to support you with technical design, quotation preparation and project execution – **reliably and always in the best interest of your customer relationships.**

Do you have a customer who needs our solution?

Reach out to our local sales teams!

dach@rr-fischer.com

uk-ireland@rr-fischer.com

france@rr-fischer.com

italy@rr-fischer.com

iberia@rr-fischer.com

benelux@rr-fischer.com

scandinavia@rr-fischer.com

northeasturope@rr-fischer.com

southeasturope@rr-fischer.com

RR Fischer GmbH
Otto-Hahn-Str. 2, 50169 Kerpen

Phone +49 2237-67806-0

Email info@rr-fischer.com

Web www.rr-fischer.com